

OVAL 1 STONE

PANADERO



MAßE

MAßE H x B x T **1048x605x490 mm**

GEWICHT
BRUTTO/NETTO **174/159 kg**

MAßE FEUERRAUMTÜR **355x440 mm**

DURCHMESSER DES
ABGASSTUTZEN **Ø 150-153 mm**
Oben

EIGENSCHAFTEN

ROST AUS GUSSEISEN

NENNLEISTUNG **8,7 KW**

WIRKUNGSGRAD **80,7 %**

CO - EMISSIONEN **0,12 %**

HITZESCHUTZANSTRICH **800°C**

GLASKERAMIKSCHEIBE
HITZEBESTÄNDIG BIS **750°C**

EAN 8426964183108
REF. PANADERO 18310

PRODUKT PLUS

ECODESIGN



**EXTERNE
LUFTZUFUHR**



260
m³ RAUMHEIZVERMÖGEN



VERMICULIT
AUSKLEIDUNG



SCHEIBENSPÜLUNG



DREIFACHVERBRENNUNG



SCHEITLÄNGE 50 CM



HOLZFACH



DOPPELBLECHGEHÄUSE
4 + 2 MM



NATURSTEIN

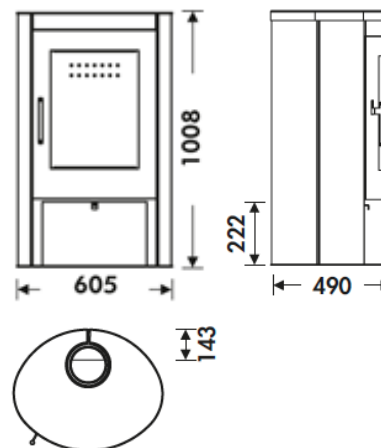

OVAL 1S DE

